

## Masters Communications Products

(Recommended solution for SHARES Gateway and Client Stations that do not have transceivers with built-in sound card capability)

### Sound Card Interfaces:

(Chose one sound card option below to add Vara HF capability to transceiver)

Product	Description	Price (assembled and tested)
DRA-100-DIN6	High performance sound card interface, front panel level controls, black or silver metal case, Mini DIN-6 radio connector.	\$175.00
DRA-100-RJ45	Same as above but with radio configuration jumper block and RJ45 radio connector.	\$175.00
DRA-36	High performance sound card interface without front panel controls, metal case, Mini DIN-6 radio connector.	\$101.00

### Mixer/Multiplexers:

(Chose one option below to connect both Sound Card and PACTOR modems to transceiver, not needed for Vara HF only stations)

Product	Description	Price (assembled and tested)
DRA-3M-DIN6	Mixer / Multiplexer allows multiple sound cards and / or TNC's to be connected to one radio simultaneously. Uses Mini DIN-6 connectors on both inputs and radio connections.	\$95.00
DRA-3M-RJ45	Same as above but uses Mini DIN-6 connectors on inputs, with radio configuration jumper block and RJ45 radio connector.	\$95.00

### Cables:

Product	Description	Price
DRAC-12	High-quality, male-male, 6-foot Mini DIN-6 cable.	\$12
DIN6-Shortie	High-quality, male-male, 3-foot Mini DIN-6 cable.	\$10

### Notes:

Both the DRA-100-RJ45 and the DRA-3M-RJ45 use the same radio connector pinout and configuration jumpers as the Tigertronics Signalink™ USB. Radio cables and configuration jumpers are available from Tigertronics. USB cables are included with each DRA, radio cables must be ordered separately. Shipping charges will be added to all orders.

### Links:

Masters Communications <http://www.masterscommunications.com/>

Tigertronics cables and configuration jumpers [https://www.tigertronics.com/sl\\_wire.htm](https://www.tigertronics.com/sl_wire.htm)

Farallon Electronics <http://www.farallon.us/webstore/>

## Radio Cables

### Stations without PACTOR Modems:

Stations that will be running Vara HF only (no PACTOR) do not require a DRA-3M mixer/multiplexer.

Choose the appropriate DRA-100 model based on the transceiver data connector. Transceivers that have the "standard" Mini DIN-6 data connector should use the DRA-100-DIN6, and then use either a Masters Communications DRAC-12 (6') or DIN6-Shortie (3') cable to connect the DRA-100-DIN6 to the transceiver. If front panel controls are not desired, the DRA-36 is a lower cost option.

For transceivers that use a different data connector, use the DRA-100-RJ45 and select the appropriate configuration jumper and radio cable from Tigertronics. If front panel controls are not desired, other DRA options are available with configuration jumpers and RJ45 radio connectors. Contact Masters Communications for assistance.

### Stations with PACTOR Modems:

Stations running both Vara HF and PACTOR will require a DRA-3M Mixer/Multiplexer to allow both the Sound Card and the PACTOR modem to be connected to the radio at the same time.

Stations that have transceivers that use the "standard" Mini DIN-6 data connector should use the DRA-3M-DIN6 Mixer and either the DRA-100-DIN6 or the DRA-36 Sound Card interface. The current cable from the PACTOR modem will be reused and will connect to the DRA-3M-DIN6 instead of the radio. A Masters Communications DRAC-12 (6') or DIN6-Shortie (3') cable can be used to connect the DRA-100-DIN6 or DRA-36 to the DRA-3M-DIN6, and to connect the DRA-3M-DIN6 to the transceiver.

Stations that have transceivers that use a different data connector should use the DRA-3M-RJ45 Mixer and either the DRA-100-DIN6 or the DRA-36 Sound Card interface. A 5-pin DIN to 6-pin mini DIN cable will be needed to connect from the PACTOR modem to the DRA-3M-RJ45 (Farallon #8120). A Masters Communications DRAC-12 (6') or DIN6-Shortie (3') cable can be used to connect the DRA-100-DIN6 or DRA-36 to the DRA-3M-RJ45. Then select the appropriate configuration jumper and cable from Tigertronics to connect the DRA-3M-RJ45 to the transceiver.

### Notes:

A 5-pin DIN to 6-pin Mini DIN6 cable that will connect from the PACTOR modem to the DRA-3M is available from Farallon Electronics, part number 8120. **All DRA internal jumpers should be set to the "1200" position (both mixer and sound card).**

A typical connection diagram using DIN-6 connections:

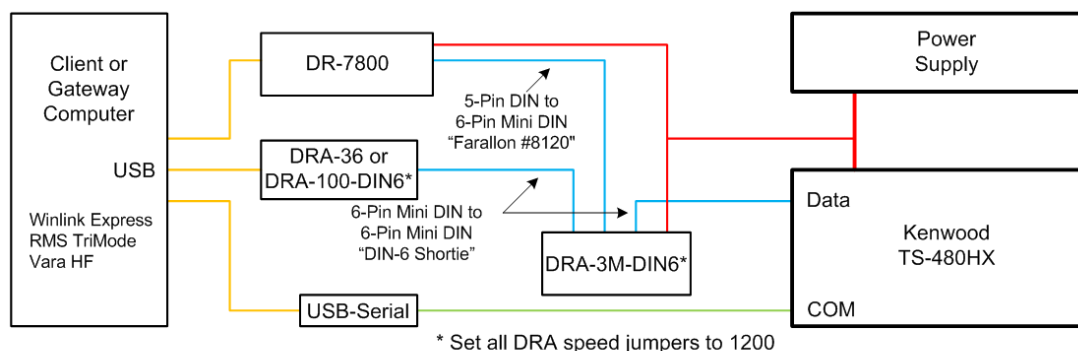

- RS232
- USB
- Audio/PTT
- 13.8 vdc

## SHARES HF RMS Block Diagram

A typical connection diagram using RJ45 connections:

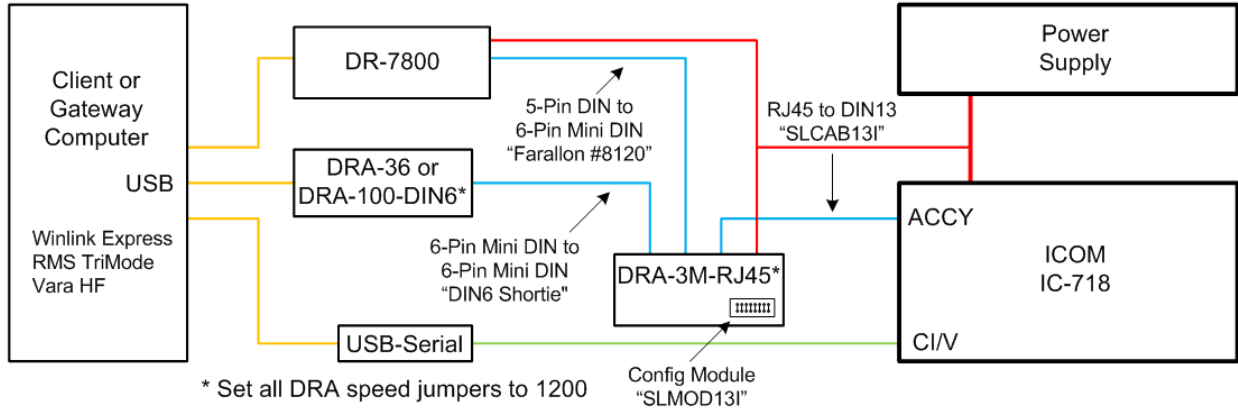

- RS232
- USB
- Audio/PTT
- 13.8 vdc

## SHARES HF RMS Block Diagram